

Model CH 10.5 30I



- Servo-Driven Vertical Collation System
- Balcony Style Machine (GMP Design)
- Patented Dynamic Product Buckets
- Servo Adjustable Carton Cell Chain
- Swivel Mounted HMI
- Elau or Allen Bradley Architecture



Carry-in Feature

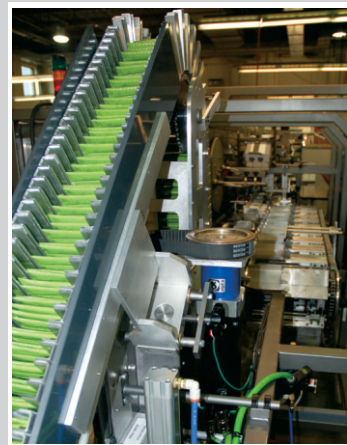

Vertical Collator



SPM (800 Sticks Per Minute)



MANUFACTURERS OF PACKAGING
AND AUTOMATED EQUIPMENT
www.zautomation.com

CH10.5-30I SPECIFICATIONS

Rated Speed	800 Sticks per Minute
Product Loading	Intermittent
Product Feed	Servo Driven Infeed Conveyor
Machine Width	6 ft
Machine Length with Product Collation	24.2 ft
Approx. Machine Weight	6,000 lbs
Carton Placing System	4 Spindle Rotary Feeder
Carton Feed	6 ft Carton Magazine
Carton Pick-Off Vacuum	PIAB 100
Settings	Scales, Position Indicator
Compression	Plowing
Hold Down	Top Rail
Zero Access Guarding	Lexan
Main Drive	ELAU Servo Motors
Supply Voltage	480 Volt, 3 Phase, 60 Hertz
Air Supply	16-18 CFM@ 80 psi
PLC Controller	ELAU PacDrive C400
Operator Interface	10.4" Magelis Color Touch Screen
NEMA Rating	12

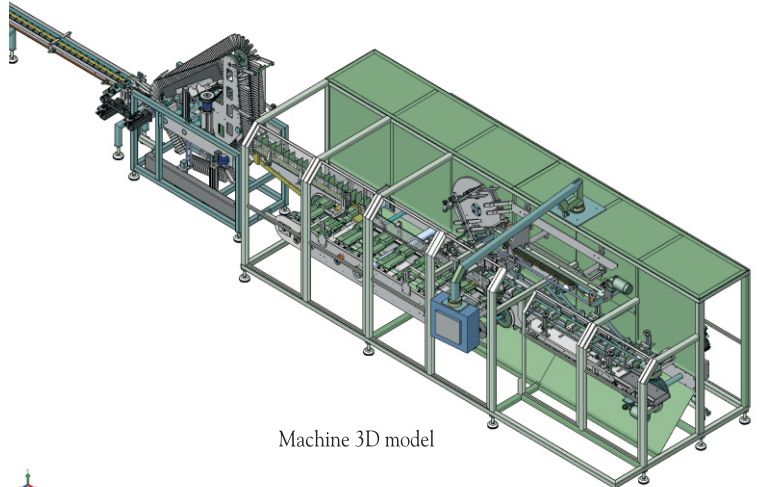

Machine 3D model

Machine floorplan

