

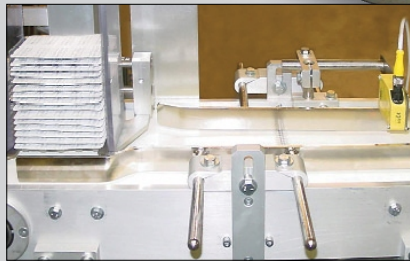

Z Automation Company, Inc.

HORIZONTAL INTERMITTENT MOTION CARTONING MACHINE

Model CH7.5-10I

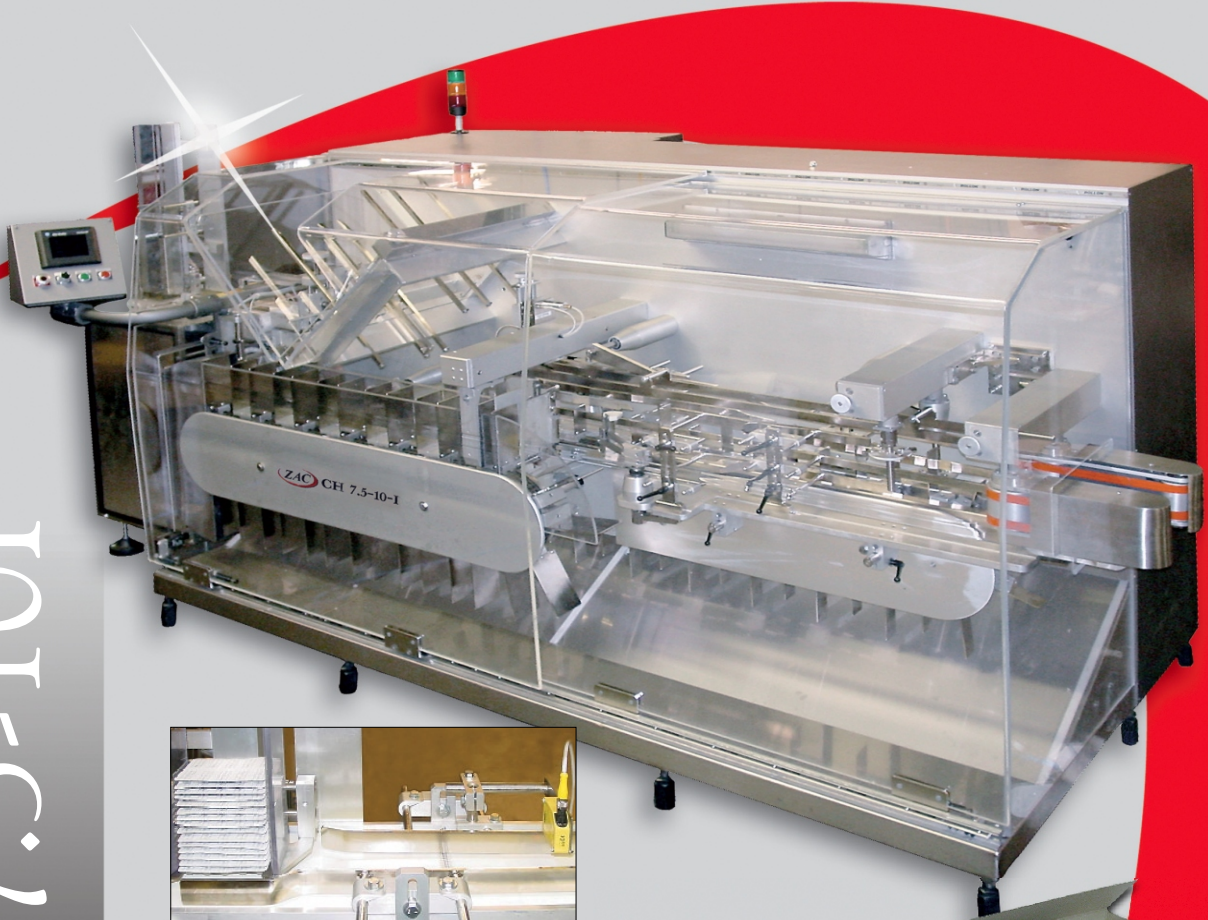

Industry's Highest Stacking Capability

- Quick Changeover Carton Pockets
- Balcony Style Machine (GMP Design)
- Easy Access Rear Drive



MANUFACTURERS OF PACKAGING
AND AUTOMATED EQUIPMENT
www.zautomation.com

CH7.5-10I SPECIFICATIONS

Rated Speed	150 Blisters Per Minute
Blister Stack Max. Height	200mm
Mechanical Cycle Speed	20 Cartons Per Minute
Production Speed	10 Cartons Per Minute
Aprox. Machine Weight	3,000 lbs
Machine Pitch	7-1/2"
Carton Size (format1) mm	90 (l) x 95 (w) x 120 (d)
CartonSize (format2) mm	90 (l) x 160 (w) x 120 (d)
Blister Size (format1) mm	76 (l) x 5.0 (w) x 116 (d)
Blister Size (format2) mm	76 (l) x 9.2 (w) x 116 (d)
Main Drive	1-1/2 hp
Product Infeed	Pre-Accumulation System With Swing Arm
Carton Magazine	2 Foot Manually Loaded
Carton Placing	Reciprocating System
Product Loading	Intermittent Motion Reciprocating System
Product Stacking System	90° Pivot Magazine
Carton Cell Chain	Intermittent Motion
Closing	Tuck/Reverse -Tuck Carton Closing
Feature	Low Carton Supply Indicator
Operator Interface	Color Touch Screen AB Panel View 600
Controller	Allen Bradley SLC 5/03
Wiring	208 V-60 Hz - 3 Phase

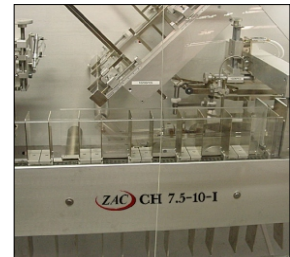
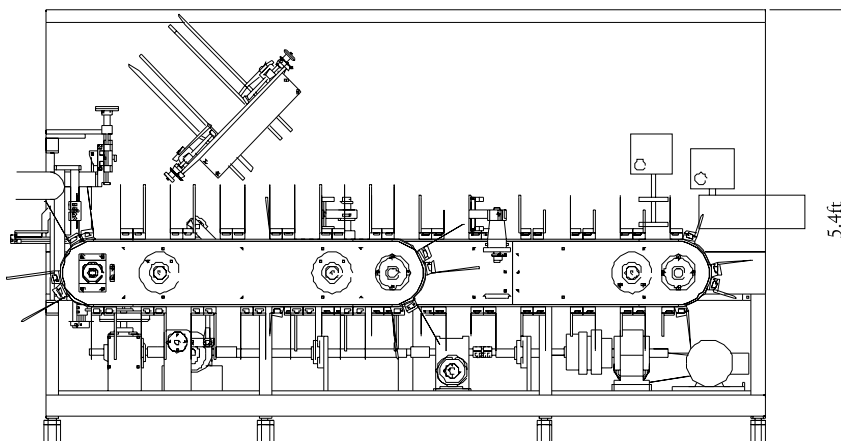
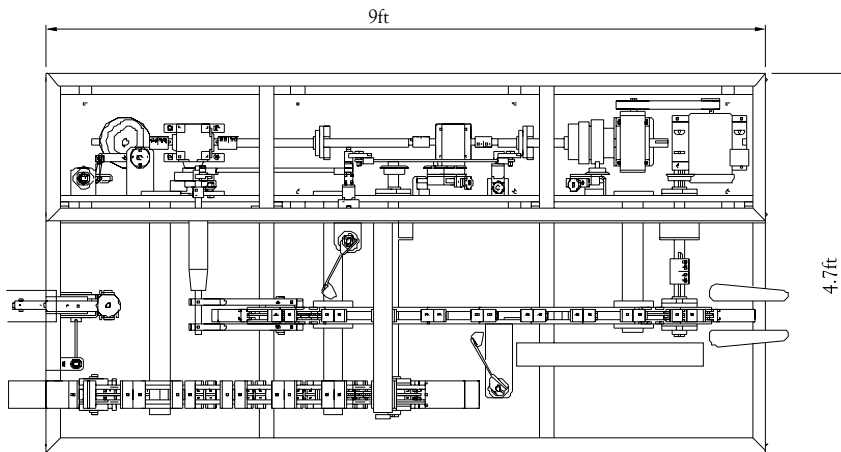
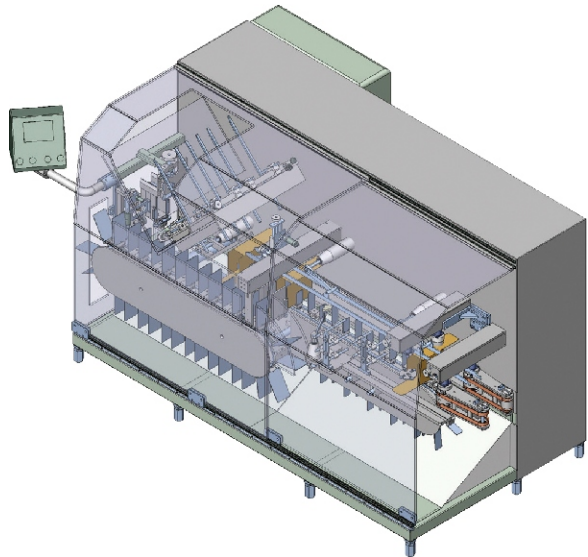

Quick Changeover
Carton Pockets

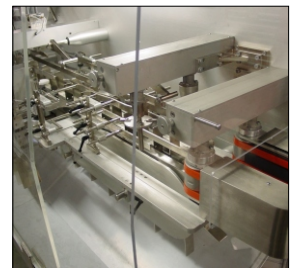

Balcony Style Machine
(GMP Design)



Easy Access Rear Drive