



Z Automation Company, Inc.

VERTICAL CARTONING MACHINE



First Commercialized COMPOSIGARD (INTEGRAPAK®) Package on the Market

- Slot Count Filling Technology
- Unique Carton Closing System
- Tool-Less Funnel Changeover

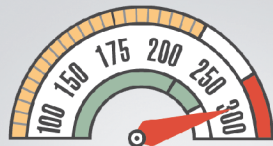

CPM (Cartons Per Minute)

MANUFACTURERS OF PACKAGING AND AUTOMATED EQUIPMENT

www.zautomation.com



Model CV4-300C



Z Automation Company, Inc.



VERTICAL CARTONING MACHINE

CV4-300C SPECIFICATIONS

Rated Speed	300 cpm
Aprox. Machine Weight	8,000 lbs
Machine Pitch	4"
Min. - Max. Carton Length	1-3/8" - 3-1/2"
Min. - Max. Carton Width	5/8" - 1-1/2"
Min. - Max. Carton Depth	1-3/4" - 8-1/2"
Max. Flap Length	1-1/2"
Min. Flap Length	3/8"
Main Drive	5hp
Carton Feed	Six Head Rotary Feeder
Product Feed	20 Spout Volumetric Filler
Product Filler	20 Funnels
Carton Magazine	Custom, 8 ft.
Funnels Changeover	No Tool (Quick Change)
Pocket Changeover	Fasteners
Carton Pick-Off Vacuum	PIAB50
Operator Interface	Panel View 1000 Touch Screen
Controller	Allen Bradley
Glue System	Nordson Pro Blue 7 (Gun Hot - Melt System)
Code Dater	Embossing Wheel Unit

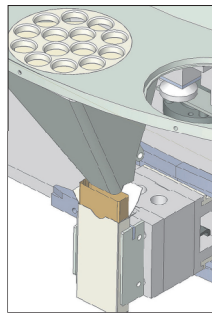

3-D Model of Volumetric Filler Count

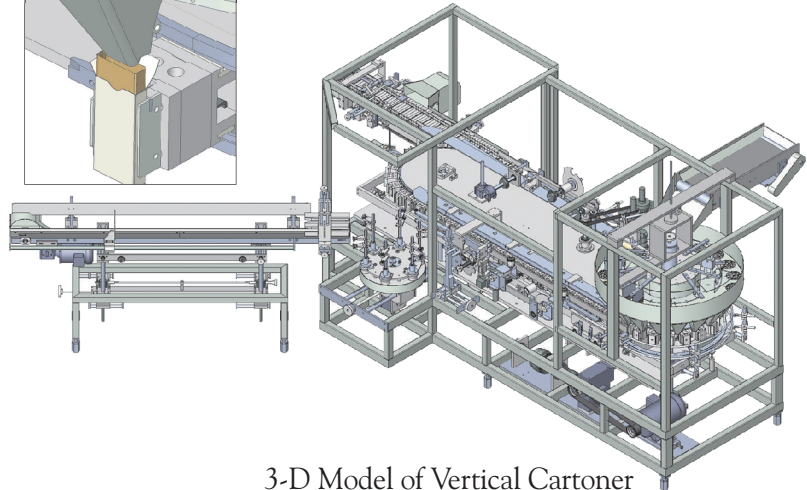

3-D Model of Vertical Cartoner

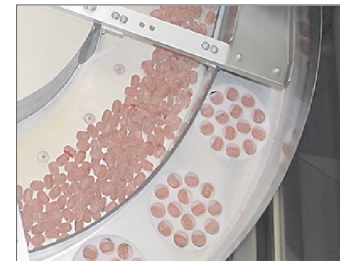
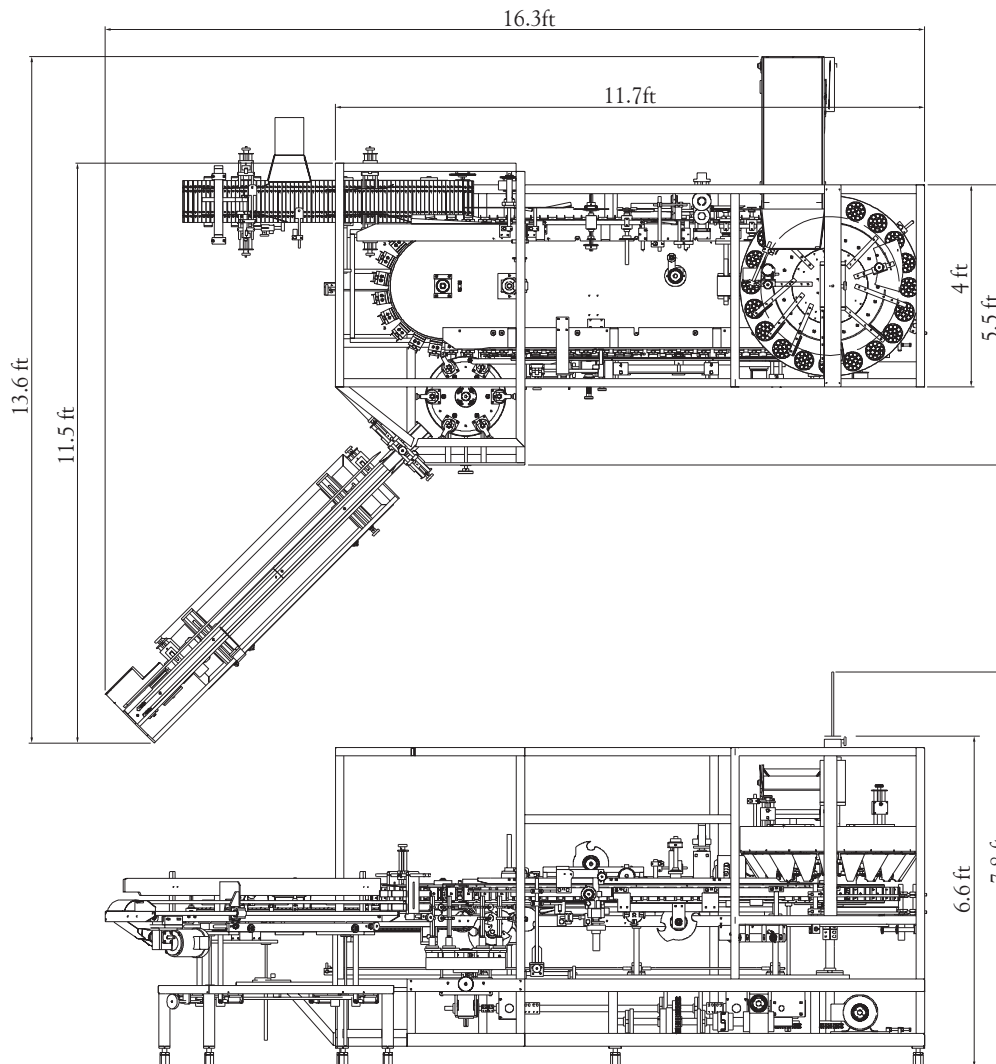

Slot Count Filling Technology



Unique Carton Closing System

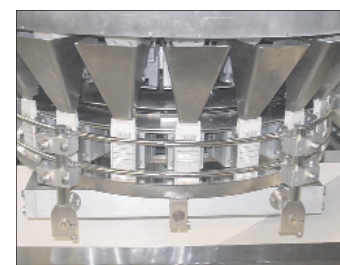

Tool-Less Funnel Changeover